



MOLYKOTE
FROM DOW CORNING

Smart Lubrication™

Synthetic Vacuum Pump Oil Resists Emulsification, Lasts Longer, Avoids Costly Cleaning in Meat Processing Plant

CASE HISTORY

Plant Lubricants

Application

Lubrication of Beach-Russ Vacuum Pump servicing a mixing chamber for lunch meats.

Problem

Exposure to high levels of water vapor in the air being removed from a food processing chamber caused premature failure of the mineral oil used to lubricate the vacuum pump under ordinary operating conditions. The mineral oil would emulsify with the water thereby degrading its performance as a lubricant.

Product Selected

Molykote® L-1668FG Synthetic Vacuum Pump Oil

Results

Instead of changing the mineral oil prematurely (weekly) to avoid machine cleanup and lost production time, the synthetic oil permitted pump operation with no change for its normal useful life of six months. Emulsification, which could diminish the efficiency of the vacuum pump, was virtually eliminated. Also, the efficiency of the vacuum pump was improved because the synthetic product maintained a better seal between rotating components.

Molykote® L-1668FG Synthetic Vacuum Pump Oil

Lubricating your vacuum pump with Molykote L-1668F Synthetic Vacuum Pump Oil is a cost-effective way to prevent premature lubricant failure and extend maintenance intervals. Unlike oils made in conventional fractionation processes, the synthetic oil is made by combining smaller molecular “building blocks” to meet targeted performance specifications and to minimize impurities. For this reason, the synthetic oil inherently resists emulsification, resulting in more effective lubrication and less frequent need for oil changes.

A meat processing plant in the Midwestern U.S. operates a Beach-Russ vacuum pump to remove excess water vapor and air from an enclosed mixing chamber. Meat material inside the chamber is extruded into a loaf shape. It is important to maintain a vacuum in the chamber to prevent formation of air pockets in the loaf. Air pockets would interfere with uniform slicing and weighing of the product.

The plant was experiencing premature oil failure with a mineral oil product used in the vacuum pump. The oil, produced in a conventional fractionation process, contained additives that were prone to attract and mix with water vapor in the air evacuated from the chamber. This attraction caused the oil to emulsify and create a water-oil mixture with a thick, sticky consistency.

The emulsified mixture would fail to lubricate the pump properly and gradually the vacuum condition inside the chamber would be degraded. If the condition were neglected, the mixture would build up inside the pump, requiring a costly and time consuming manual cleaning. This condition can also lead to varnish deposits inside the pump as heat rises, which would shorten pump lifetime and require rebuilding of the pump in less than a year.

In order to forestall such a possibility by preventing emulsification, the plant's maintenance manager was changing the conventional mineral oil product every week.

Synthetic Food-Grade Product

To improve pump lubrication and simplify maintenance, the plant switched to Molykote® L-1668FG Synthetic Vacuum Pump Oil, a Dow Corning product. Unlike oils made in conventional fractionation processes, the synthetic oil is made by combining smaller molecular “building blocks” to meet targeted performance specifications and to minimize impurities.

The custom-blended polyalphaolefin (PAO) synthetic oil gives excellent lubrication at high and low temperatures, reduced volatility and compatibility with equipment designed for use with mineral oils. It conforms to USDA listing requirements applicable to meat and poultry plants and is qualified for direct food contact under FDA regulations.

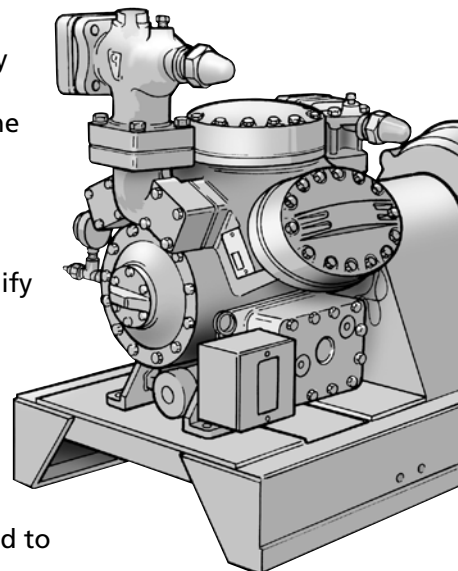

The food-grade formulation was chosen because its higher purity and absence of additives made it less likely to mix with moisture and emulsify. During a trial period, the oil was tested at intervals for 15 weeks and then allowed to run its full rated lifetime of 26 weeks before changeout. At 15 weeks the oil's condition was rated "good" in spite of 4 percent water content because the water did not emulsify or degrade the oil. Anti-oxidant, pH, viscosity and corrosion values were all acceptable.

Long-Range Benefits

By switching to the synthetic food-grade product the plant reduced the need for oil changes on the vacuum pump from once per week to once per six months. Formation of emulsified oil-water mixture and associated varnish deposits on pump internal parts have been virtually eliminated. The pump is ordinarily expected to operate for ten years before needing a rebuild. The plant saves time formerly needed for periodic dismantling and cleaning the pump interior. The pump more reliably maintains the seal needed to maintain vacuum conditions in the chamber.

Plant management adopted a policy of using only food-grade synthetic PAO products for MRO needs. Although in many cases these products exceed the unit cost of the conventional mineral oils they replace, their superior performance more than makes up for the difference. Standardizing on food-grade products also eliminates the possibility that plant workers will confuse one type of oil with another.

Benefits to Food Processing Plants

- Reduce use of lubricant
- Extend interval between oil change
- Simplify record-keeping for Hazard Analysis and Critical Control Point (HACCP)
- Maintain better vacuum pump performance
- Eliminate need for manual pump cleaning caused by emulsification of oil
- Extend pump lifetime by preventing varnish buildup and wear caused by emulsification
- Protect food product from contamination by non-food-grade lubricant

WARRANTY INFORMATION

The information contained herein is offered in good faith and is believed to be accurate. However, because conditions and methods of use of our products are beyond our control, this information should not be used in substitution for customer's tests to ensure that Dow Corning's products are safe, effective, and fully satisfactory for the intended end use. Dow Corning's sole warranty is that the product will meet the Dow Corning sales specifications in effect at the time of shipment. Your exclusive remedy for breach of such warranty is limited to refund of purchase price or replacement of any product shown to be other than as warranted. Dow Corning specifically disclaims any other express or implied warranty of fitness for a particular purpose or merchantability, unless Dow Corning provides you with a specific, duly signed endorsement of fitness for use. Dow Corning disclaims liability for any incidental or consequential damages. Suggestions of use shall not be taken as inducements to infringe any patent.

Dow Corning and *Molykote* are registered trademarks of Dow Corning Corporation.

We help you invent the future is a trademark of Dow Corning Corporation.

©2000 Dow Corning Corporation. All rights reserved.

Printed in USA

AGP12459

Form No. 10-1002A-01

DOW CORNING

We help you invent the future.[™]